

Molding Power Inductors -MTH Series

MTH Series



欣腾辉电子
XINTENGHUI ELECTRONICS



Description:

- RoHS,Halogen Free and REACH Compliance
- High current carrying capacity,Low core losses
- Powder iron core material
- Frequency range up to 5MHZ.
- Magnetically shielded, low EMI

Applications:

- Switches and servers
- SSD modules
- Notebook regulators
- Battery power systems
- DC/DC converters

Product Identification

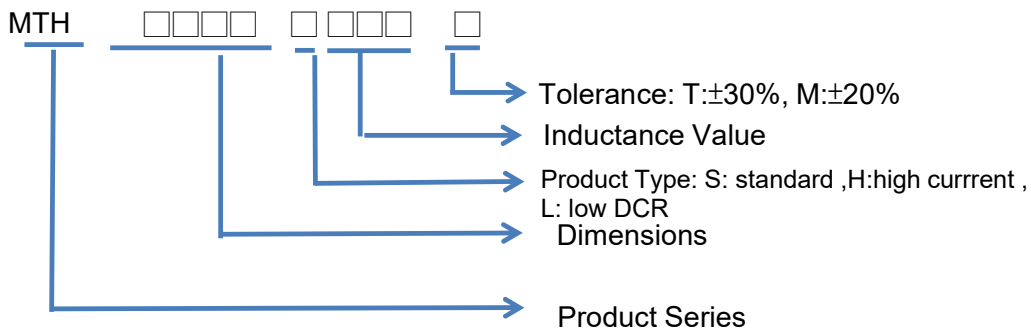

Dimensions-mm

Shape and Dimensions

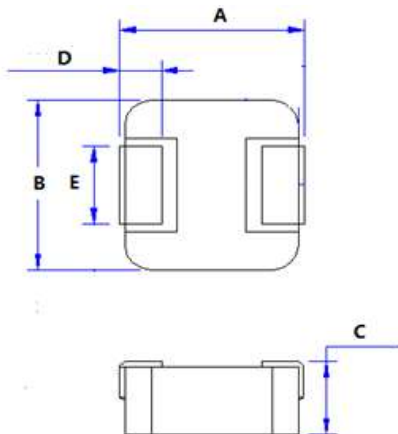

Recommended Pad Layout

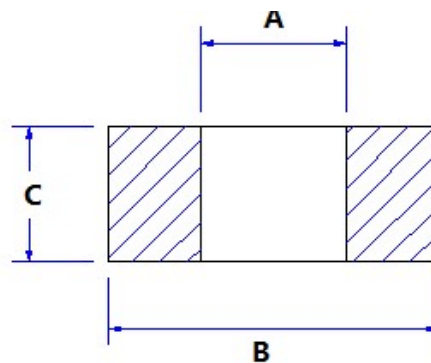

Dimensions-mm

TYPE	A	B	C	D	E
0618	7.0±0.3	6.6±0.2	1.6±0.2	1.6±0.3	3.0±0.3

Dimensions-mm

TYPE	A	B	C
0618	3.7	8.4	3.5

Molding Power Inductors -MTH Series

Electrical Characteristics

Part No.	Inductance (μH)	Tolerance (%)	Test Freq.	RDC(mΩ) Max.(Typ)	Irms(A) Typ.	Isat(A) Typ.
MTH0618SR10M	0.10	20	100KHZ,1V	2.3(2.0)	25.0	38.0
MTH0618SR22M	0.22	20	100KHZ,1V	3.5(3.0)	22.0	24.0
MTH0618SR47M	0.47	20	100KHZ,1V	8.4(8.0)	11.5	18.0
MTH0618SR68M	0.68	20	100KHZ,1V	12.0(10.0)	9.5	17.0
MTH0618S1R0M	1.0	20	100KHZ,1V	16.0(13.0)	8.5	14.0
MTH0618S1R5M	1.5	20	100KHZ,1V	26.0(20.0)	8.0	9.2
MTH0618S2R2M	2.2	20	100KHZ,1V	35.0(28.0)	7.0	8.0
MTH0618S3R3M	3.3	20	100KHZ,1V	50.0(43.0)	4.5	6.5
MTH0618S4R7M	4.7	20	100KHZ,1V	62.0(56.0)	4.0	5.0
MTH0618S6R8M	6.8	20	100KHZ,1V	110.0(101.0)	3.0	4.5
MTH0618S100M	10.0	20	100KHZ,1V	155.0(140.0)	2.3	2.5
MTH0618S220M	22.0	20	100KHZ,1V	350.0(310.0)	1.8	2.3

Notes:

- 1.All test data is referenced to 25°C ambient.
- 2.Operating temperature range -55°C to +125°C (Including self - temperature rise)
- 3.Irms(A):DC current(A) that will cause an approximate ΔT of 40°C (reference ambient temperature is 25°C)
- 4.Isat(A):DC current(A) that will cause L0 to drop approximately 30%.
5. Measure Equipment :
L : Wayne kerr 3260B/G LCR Meter (or equivalent), 100KHz 1.0V
RDC : CHEN HWA502BC/HP4338B (or equivalent)
Isat : Wayne kerr 3265B Bias Current Source (or equivalent)
Irms : Wayne kerr 3265B Bias Current Source (or equivalent)
- 6.Test Condition:
Temperature:26±3°C
Humidity:<70% RH
Frequency:100KHz 1.0V
7. Absolute maximum voltage 50VDC

Molding Power Inductors -MTH Series

Curve:

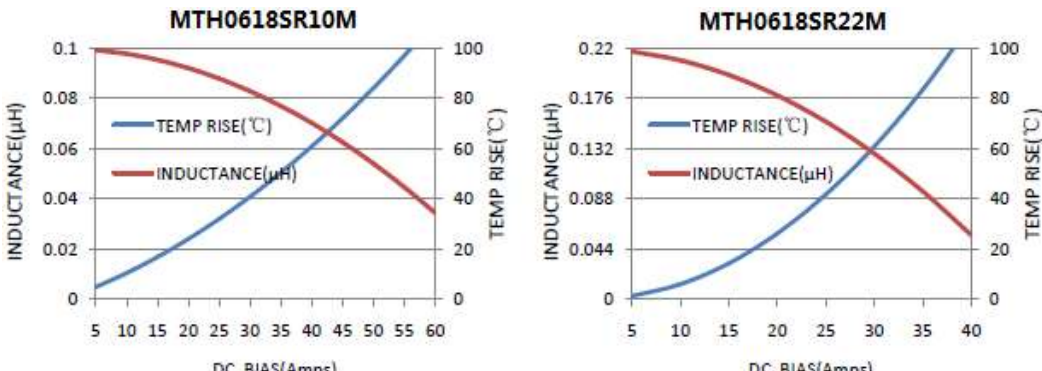

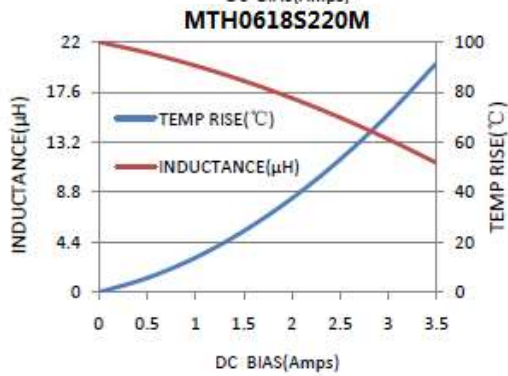
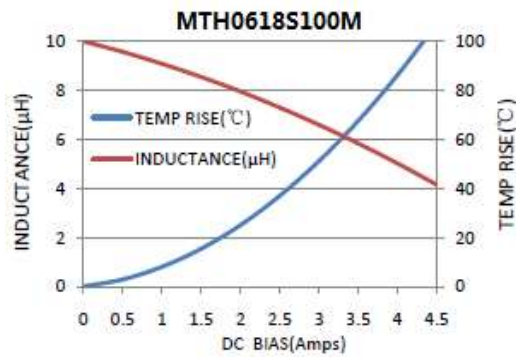
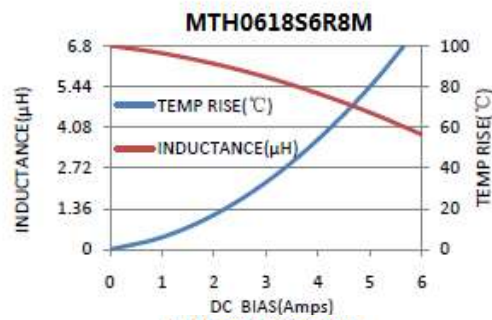
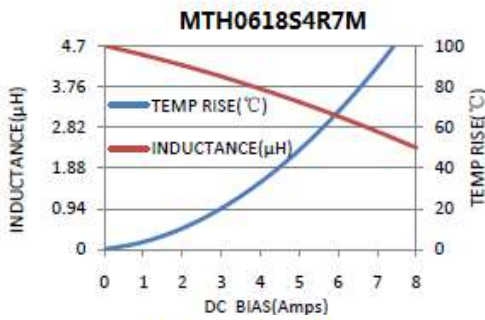
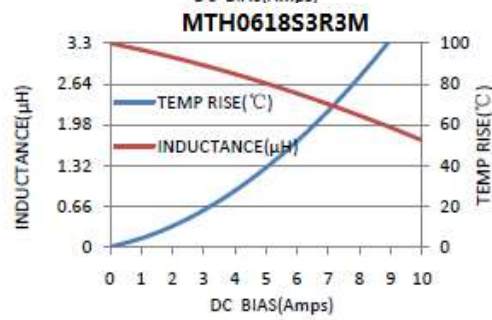
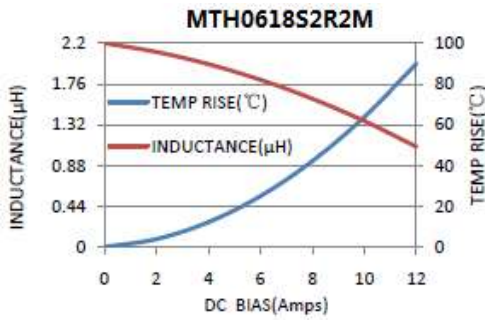
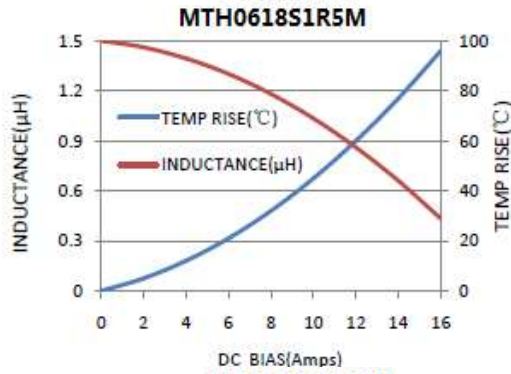
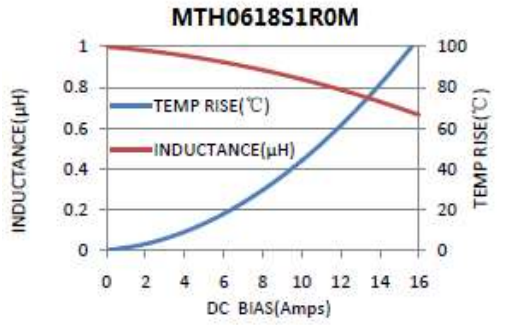
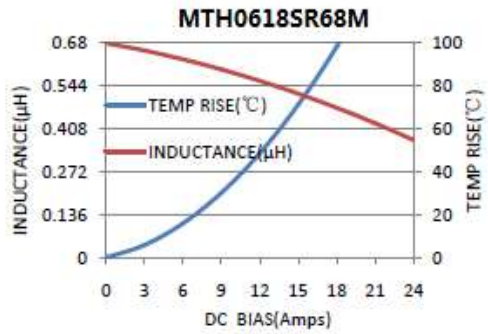
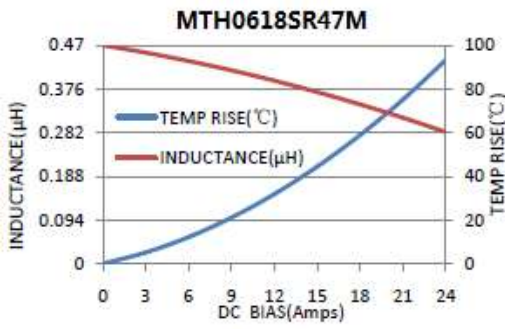

Molding Power Inductors -MTH Series

Packaging:

Packaging -Cover Tape

The force for tearing off cover tape is 10 to 130 grams in the arrow direction.



Packaging Quantity

TYPE	PCS/REEL
MTH0618	1500

Reel Dimensions

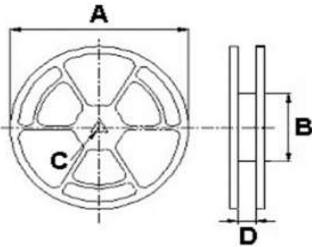

Reel Dimensions:mm

TYPE	A	B	C	D
MTH0618	330	100	13	16

Tape Dimensions in mm

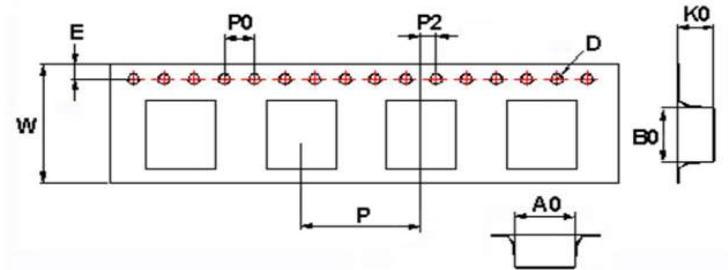

TYPE	A0	B0	K0	D	E	W	P	P0	P2
MTH0618	6.9	7.6	2.2	1.55	1.75	16	12	4	2