

产 品 承 认 书
SPECIFICATION FOR APPROVAL

客户名称
CUSTOMER NAME.

产品类型 共模电感
PRODUCT TYPE

客户料号 SCML2010C-SERIES
CUSTOMER P/N

料号 SCML2010C-SERIES
OURS P/N

文件编号
FILE NO.

批准 APPROVED	确认 CHECKED	作成 DESIGN
chen	lin	ming

客户承认/CUSTOMER ACCEPTED		
承认 APPROVED	确认 CHECKED	承办 DESIGN
批注/REMARK		

苏州欣腾辉电子有限公司
SUZHU XINTENGHUI ELECTRONIC CO., LTD.

承认书/SPECIFICATION FOR APPROVAL

客户名称 CUSTOMER		客户品名 CUSTOMER P/N	SCML2010C-SERIES	版别 REV.	A
产品类型 PRODUCT TYPE	共模电感	品名 OURS P/N	SCML2010C-SERIES	文件编号 FILE NO.	

四. 材料清单/MATERIAL LIST

NO.	ITEM	DESCRIPTION
1	CORE	FERRITE
2	CASE	PM9630
3	WIRE	P180 Grd1
4	SOLDER	Sn99.3:Cu0.7
5	ADHESIVE	XNR-3614
6	INK	WHITE

五. 编带规格/TAPING SPECIFICATIONS

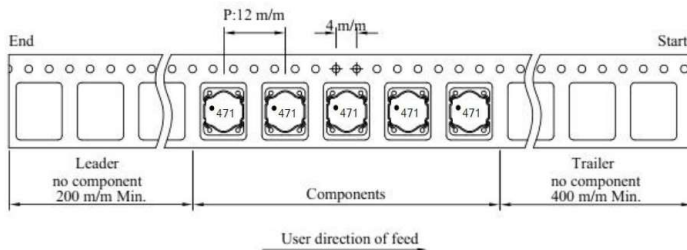

Transparent carrier and cover tape/透明载带和自粘上带

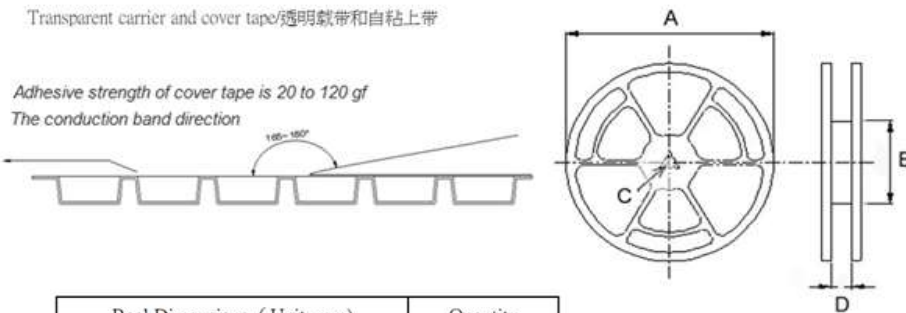

Reel Dimensions (Unit: mm)				Quantity
A	B	C	D	Pcs/Reel
330	100	13	32.5	180

拟制	ming	审核	lin	批准	chen
----	------	----	-----	----	------

承认书/SPECIFICATION FOR APPROVAL

客户名称 CUSTOMER	0	客户品名 CUSTOMER P/N	SCML2010C-SERIES	版别 REV.	A
产品类型 PRODUCT TYPE	共模电感	品名 OURS P/N	SCML2010C-SERIES	文件编号 FILE NO.	

七. 可靠性测试/RELIABILITY TESTING

Operating Temperature	- 40 to +125 °C (Contain Heating coil)
Appearance Inspection	No external defects by visual inspection
Terminal Strength	After soldering , between copper plaet and terminals of coils , push in two directions of X , Y with standing 10N(1.02kg) for10+/-2 sec. Terminal should not peel off. (Refer to figure at right)
Heat endurance of reflow soldering	Refer to figure
Insulating resistance	Over 100 MΩ at 100V D.C . between wire and core
Dielectric Strength	Apply at 0.5KV 3mA for 1 minute between wire and core
Temperature characteristics	Inductance coefficient (0~2,000) × 10 / °C (- 40~ + 125 °C)
Humidity characteristics	Inductance deviation within ± 10% , after 96 hours in 90~95% relative humidity at 40 ± 2 °C and 1 hours drying under normal condition

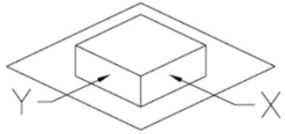

A test is made under the above mentioned condition , and it is kept for 2 hours in the normal

IR Reflow profile

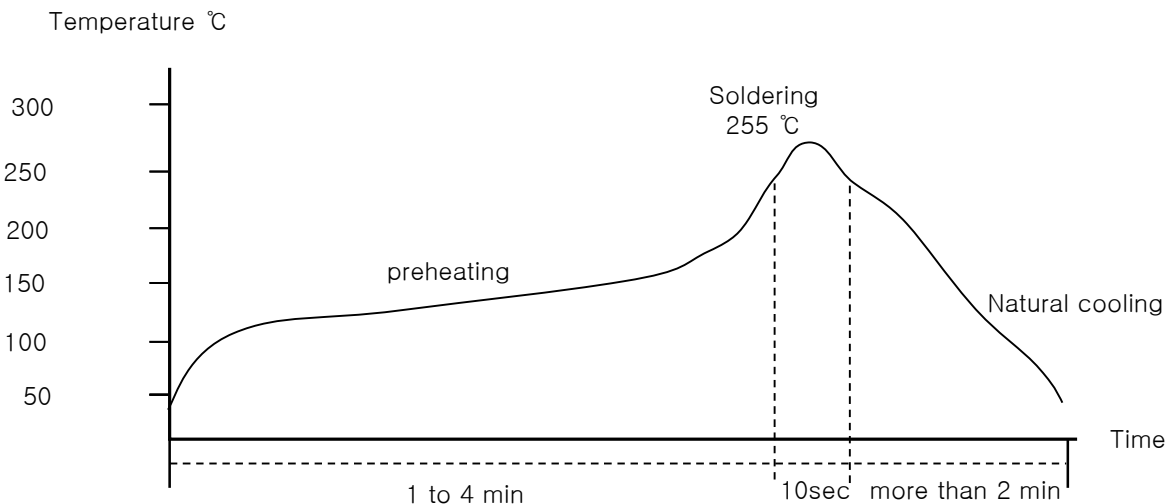

Temperature and humidity . After that , no mechanical and electrical defect should be found .

拟制	ming	审核	lin	批准	chen
----	------	----	-----	----	------

承认书/SPECIFICATION FOR APPROVAL

客户名称 CUSTOMER	0	客户品名 CUSTOMER P/N	SCML2010C-SERIES	版别 REV.	A
产品类型 PRODUCT TYPE	共模电感	品名 OURS P/N	SCML2010C-SERIES	文件编号 FILE NO.	

八. 包装方式/PACKING LIST

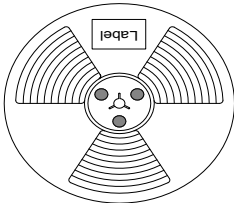
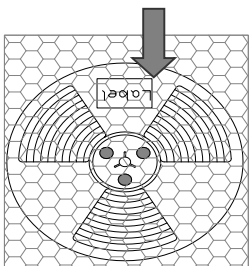
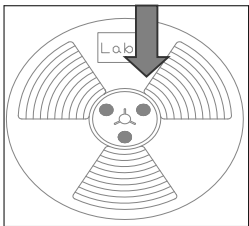
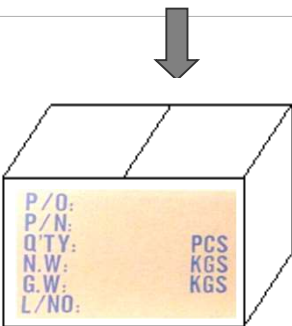
	<p>1、轮盘规格：13'(直径330mm) 数量：180PCS/盘</p>				
	<p>2、数量180PCS/袋.</p>				
	<p>3、数量180PCS/盒.</p>				
	<p>4、数量：900PCS/箱. 作业说明：当尾数箱不足一整箱时需用内盒或填充物装满.</p>				
拟制	ming	审核	lin	批准	chen