

1. ELECTRICAL SPECIFICATIONS@25°C

1.1 Insertion Loss:-1.0 dB Max @0.3-100 MHz

1.2 Return Loss:-18 dB Min @1-30 MHz

-14 dB Min @30-60 MHz

-12 dB Min @60-80 MHz

1.3 Cross Talk:-45 dB Min @1-30 MHz

-35 dB Min @30-60 MHz

-30 dB Min @60-100 MHz

1.4 Common Mode Rejection:-40 dB Min @1-30 MHz

-35 dB Min @30-60 MHz

-30 dB Min @60-100 MHz

1.5 Operating temperature 0°C to +70°C

1.6 Storage temperature range:-40°C to+105°C

Type: 10/100 BASE-T

Part no: SH1601S

惠州上禾电子科技有限公司

Rev : A

Page: 2 / 6

2. CIRCUIT SCHEMATICS

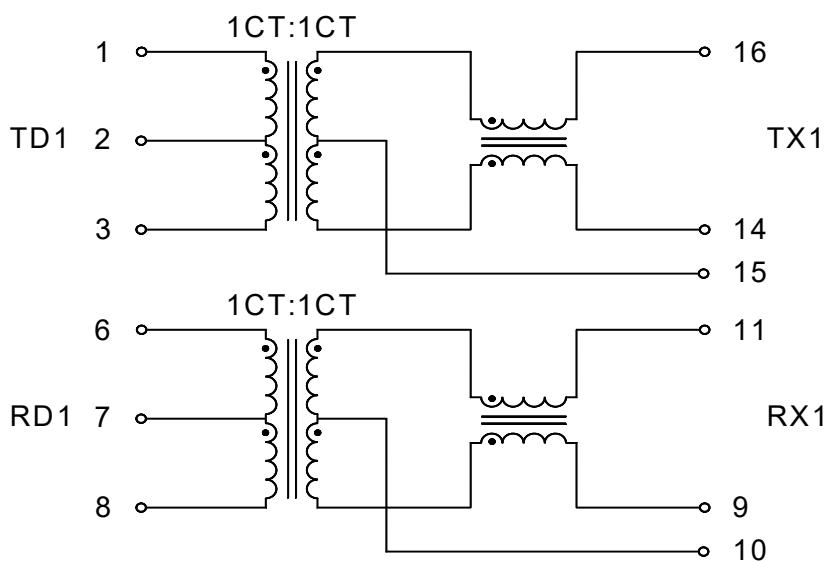

3. MECHANICAL DIMENSIONS

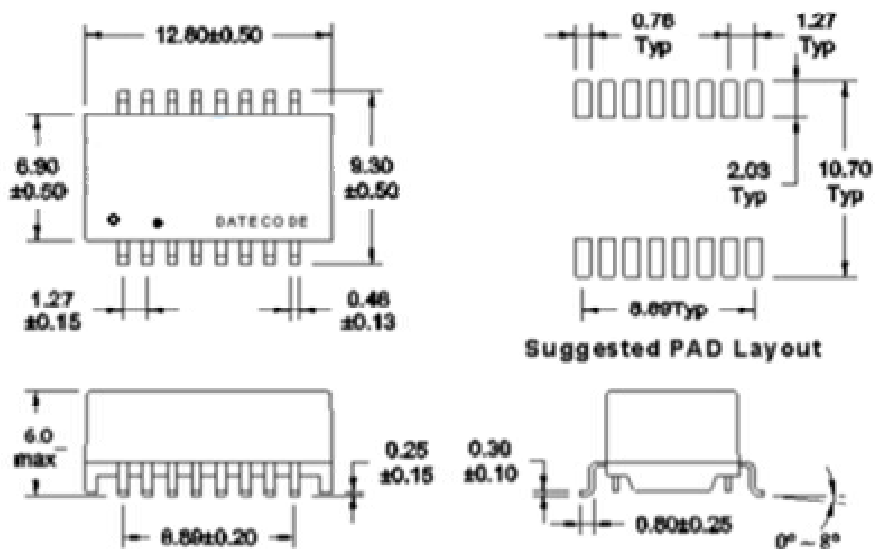

备注：圆圈为胶壳自带一脚点，实点为印字一脚点。

Type: 10/100 BASE-T

Part no: SH1601S

惠州上禾电子科技有限公司

Rev :A

Page: 3 / 6

4. MARKING SPECIFICATIONS



5. LCR TEST SPECIFICATIONS

5.1 PRIMARY INDUCTANCE(uH) @100KHz,0.1V With 8mA DC Bias

1-3	350 uH Min
6-8	350 uH Min

5.2 LEAKAGE INDUCTANCE(uH) @100KHz,0.2V

1-3(16-14short), 6-8(11-9short)	0.5 uH Max
16-15(1-2-3short), 11-10(6-7-8short)	5-45 uH

5.3 TURN RATIO(±3%) @100KHz,1V

(1-3):(16-14)= 1:1
(6-8):(11-9)= 1:1
(1-2):(2-3)= 1:1
(6-7):(7-8)=1:1
(16-15):(15-14)=1:1
(11-10):(10-9)=1:1

5.4 DC RESISTANCE(OHM)

1-3, 6-8	0.4-0.9 OHM
16-14, 11-9	0.7-1.2 OHM
1-2, 2-3	0.2-0.6 OHM
6-7, 7-8	0.2-0.6 OHM
16-15, 15-14	0.3-0.7 OHM
11-10, 10-9	0.3-0.7 OHM

Type: 10/100 BASE-T

Part no: SH1601S

惠州上禾电子科技有限公司

Rev : A

Page: 4 / 6

5.5 PHASE

1-16, 6-11

In-Phase

5.6 INTERWINDING CAPACITANCE(pF) @100KHz,0.2V

2-15, 7-10

28 pF Max

5.7 ZX(MΩ) @1KHz,1V

3-4, 4-5, 5-6, 3-6, 11-12, 12-13, 13-14, 11-14

0.5 MΩ Min

5.8 INDUCTANCE Balance(uH) @100KHz,0.2V

(16-15short1-3)-(15-14short1-3) ≤ 1.5, (11-10short6-8)-(10-9short6-8) ≤ 1.5

6. ISOLATION HI-POT

Test Condition:1500VAC,2mA,2Sec

Test Terminal:1-8 TO 9-16

7. WINDING LAYOUT

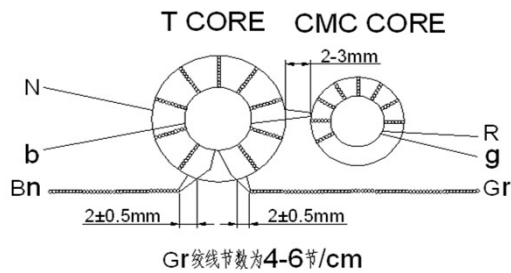
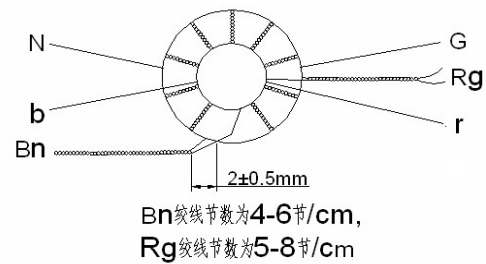
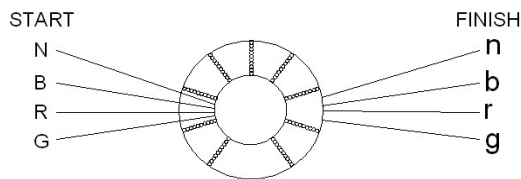

T CORE:使用H级0.09mm RRGB四线绞线部分(5-6节/cm)绕磁环 13TS,

CMC CORE:用Rg绞线绕磁环 10TS.

Type: 10/100 BASE-T

Part no: SH1601S

惠州上禾电子科技有限公司

Rev : A

Page: 5 / 6

8. SCHEMATICS

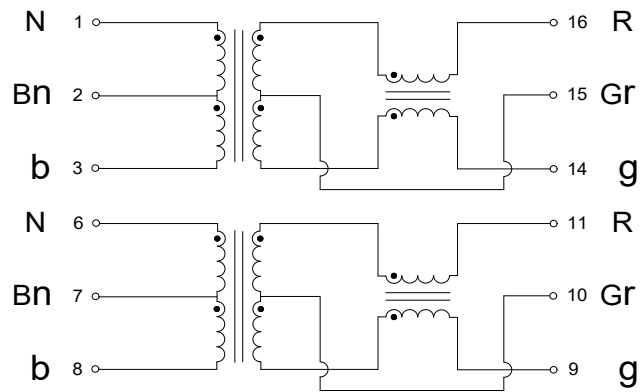

9. SCHEMATIC DIAGRAM OF THE CORE PLACED

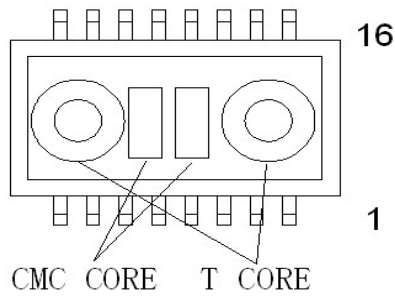

10. PACKAGE CRITERION

10.1 Carton Box

Carton Box: 34.5*34.5*31.5cm

10 PCS REEL

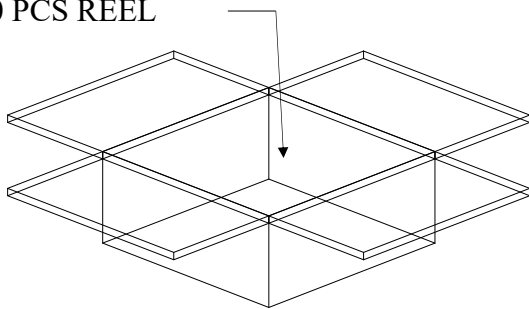

Type: 10/100 BASE-T

Part no: SH1601S

惠州上禾电子科技有限公司

Rev : A

Page: 6 / 6